

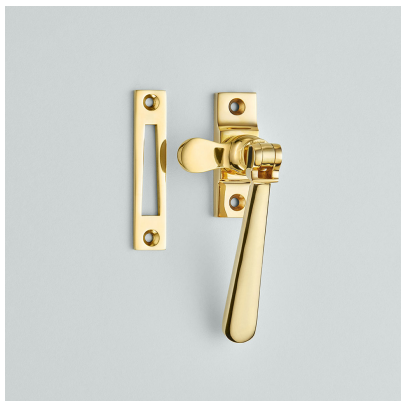

CROFT



Product Code: 1851

Product Name: Casement Fastener

Description: Locking & Weatherseal versions available.

Shown here in our Polished Brass Unlaquered finish.

Product Information

Available: With Mortice plate (MP) With Hook plate (HP) With Mortice and Hook plate (MP and HP)

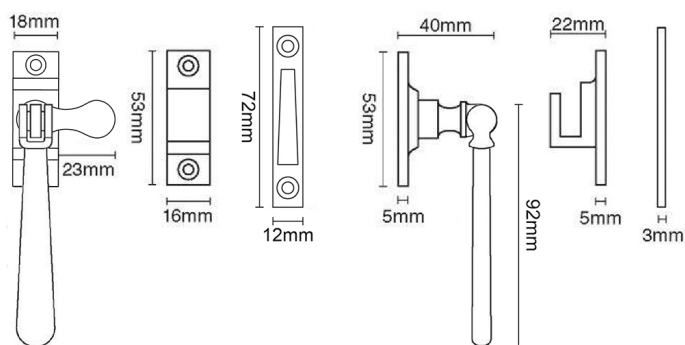

Available in all Croft finishes excluding DORB, IBMA, IBUL, MBK, ORB, RBMA, TB,