



CROFT



Product Code: 1760

Product Name: Wedge Fastener

Description: Part of our full range of window fittings. Suitable for windows fitted with a weatherseal. Locking Version available

Shown here in our Oil Rubbed Bronze finish.

Product Information

57 x 16mm backplate. 101mm handle length.

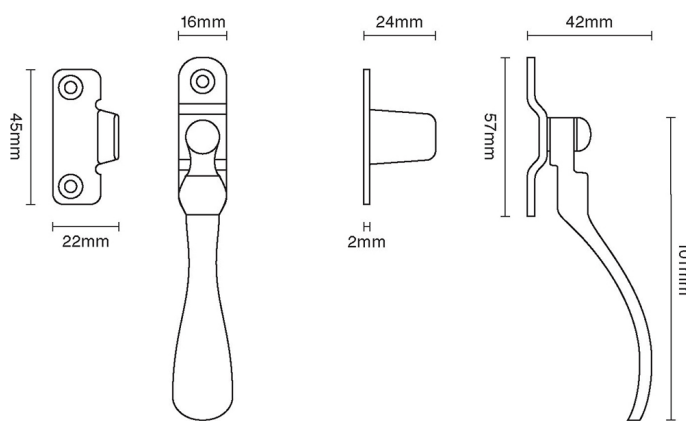

Available in all Croft finishes excluding DORB, IBMA, IBUL, MBK, ORB, RBMA, TB,